

AIRTEC

INTERNATIONAL LTD

Seben

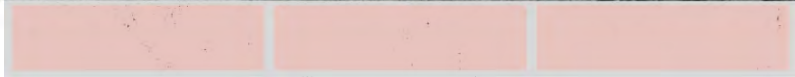

KFT

MASTER 35[®]

PETROL/GASOLINE IMPACT WRENCH

LSZ.008

CE

AIRTEC

INTERNATIONAL LTD

Couper Street, Glasgow G4 0DL United Kingdom

Tel: 44(0)141 552 5591

Fax: 44(0)141 552 5064

E-mail: enquiries@airtecinternational.co.uk

The Manual can be downloaded from our website www.airtecinternational.co.uk in English, French, German & Spanish



AIRTEC INTERNATIONAL LTD

Couper Street, Glasgow G4 0DL United Kingdom

Tel: 44(0)141 552 5591

Fax: 44(0)141 552 5064

E-mail: enquiries@airtecinternational.co.uk

Website: www.airtecinternational.co.uk

DECLARATION OF CONFORMITY

To whom it may concern:

We **Airtec International Ltd Couper Street GLASGOW G4 0DL United Kingdom**

Declare that we are solely responsible for the supply/manufacture of the

Master 35® Petrol/Gasoline Impact Wrench

1" Square Drive powered by special Emak Engine

Serial No. 17T148

Detailed information on weight, noise, vibration etc. is contained in our Operator Manual to which this declaration relates and is in conformity with the relevant standards of the undernoted European Union.

2006/42/EC

83/188/CEE

89/686/CEE

Machinery Directive

Protection of personnel against the effects of noise etc,

Personal Protection of Equipment according to Government Law DPR459/96

All of the Wrenches are fitted with a five position torque control lever covering a torque range of 500 - 1800Nm (350 - 1325 Ft/lbs) approx. Every Wrench has been individually inspected at our factory to ensure they comply with our high quality standard.

In addition to the above Laws the Wrench meets the manufacturing standard UNI EN292 relating to the principles of good Engineering practice and design.

Best regards,

GLASGOW

23/01/18

(Place and date of issue)

A. KILPATRICK

(Name and signature of authorised Person)

Directors : A. Bissoli (Italy) A. Kilpatrick Co. Sec. : A. Kilpatrick Registered in Scotland 135384

MASTER 35[®]

PETROL/GASOLINE IMPACT WRENCH

MAINTENANCE MANUAL

CONTENTS

| DESCRIPTION | PAGE NUMBER |
|--|-------------|
| Uses & Technical Information | 1 |
| Safety Precautions | 2 |
| Operating Controls – Illustrations | 3 |
| Operating Controls – Instructions for use | 4 |
| Start/Stop Operation | 5 |
| Basic Workshop Safety Rules | 6 |
| Routine Service | 7 |
| Dismantling Motor | 8 |
| Motor Parts List and Exploded Diagrams | 9 & 10 |
| Motor Notes | 11 |
| Dismantling Impact Unit | 12 |
| Motor and Carrying Handle Diagram Drawing and Parts List Impact Unit & Gearbox | 13 & 14 |
| Exploded Diagram Drawing and Parts List | 15 & 16 |
| Gearbox and Impact Unit Notes | 17 |
| Workshop Equipment | 18 |
| Accessories | 19 |
| Index | 20 & 21 |

Copyright Airtec International Ltd[®]. All Rights Reserved.
No reproduction of whole or part of this Manual is allowed without
written Permission of Copyright.
Airtec International Limited, Couper Street, Glasgow G4 3DL, U.K.

Edition June 2017

1. USES

The Master Impact Wrench is ideal for removing/fitting Chairscrews (Lag Screws) and Fishplates (Joint Bars) where track possession is not possible, if there are access difficulties or if other sources of power e.g. Air Compressors, Generators or Power Packs are not available. The Master can drill holes in Wooden Sleepers (Ties) using our Safety Quick Release Attachment which allows the fitting/removal of Auger Bits in seconds.

Fasteners can be removed/fitting in under seven seconds.

2. TECHNICAL INFORMATION

1. TORQUE RANGE

500 - 1800Nm approximately, adjustable using our five setting control knob.

It is possible to achieve higher torques of up to 2,750Nm but this can only be achieved under special conditions. The Master will loosen any screwed fastener previously tightened by any other Petrol Driven Impact Wrench.

2. BOLT CAPACITY

16 to 32mm (5/8" to 1 1/4") dia

3. DIMENSIONS

Length 570mm (22 3/8")
Height 280mm (11")
Width 445mm (17 1/2")

4. ENGINE - Two stroke/cycle Special Airtec EMAK 056 56.5 c.c.

Maximum free speed 12,000 R.P.M.
Power 3.1Kw
Fuel Tank capacity 0.7 litres (1.20 pints)
Running time on full tank of fuel 60 Minutes

Fuel Mixture ratios

Petrol/Gasoline Unleaded minimum 90
Octane and two stroke

| MIX | RATIO | MLS. PER | (OZS. PER) |
|-----------|-------|----------|------------|
| OIL | | LITRE | (US GAL.) |
| Mineral | 25:1 | 40 | 3 |
| Synthetic | 50:1 | 20 | 1 1/2 |

5. IGNITION - DIGITAL

Spark Plug Champion RCJ-7Y or equivalent
Spark Plug gap should be 0.5 to 0.6mm

6. GEARBOX

Fill with 0.25 Litre (1/2 pint) of Esso Spartan EP68, Mobil Gerar 626, Carter EP68, Merpoa 68, Valvoline 80-90W or an equivalent non synthetic 68 viscosity Gear Oil to half way up sight glass with Wrench in the horizontal position. Change Oil every twelve months.

7. IMPACT MECHANISM

Fill with 130 grammes (4 1/2 oz) of **Molybdenum Disulphate Grease**, Castrol MS3, Klubern N12MF, Valvoline NLG 1 # 2 or equivalent **Grade 2 quality**.

8. NOISE

Acoustic pressure (LpA) readings Idling 87 : dB(A) Acoustic power (LWA) according to ISO 3746 Idling 96 : dB(A)
Under very extreme working conditions the machine can reach 103 & 118 : dB(A) respectively.

Always wear ear protection

9. SQUARE DRIVE

Standard 1"

10. VIBRATION GUIDE

On extensive on-track trials carried out under the independent supervision of Loughborough University in February 2008 the undernoted results were achieved on loosening and tightening :-
Fishplate/Joint Bar Nuts
11.2 to 11.6 m/s² in approximately three seconds which equals 430 Nuts before reaching EU Action and 1800 to reach Limit Level
Chairscrews/Lagscrews
9.8 to 11.0 m/s² in approximately seven seconds which equals 240 screws before reaching EU Action and 1000 to reach Limit Level
The actual figures achieved can vary depending on operator technique and condition of Wrench, fastener, track and Socket.

11. WEIGHT

18.2 Kgs (40 lbs)

3. SAFETY PRECAUTIONS

BEFORE using the Impact Wrench read these safety instructions **CAREFULLY** and ensure you fully **UNDERSTAND** them. **DO NOT** allow untrained personnel to use the Wrench.



1. Wear suitable **PROTECTIVE CLOTHING**, safety boots, goggles, gloves and ear protection according to Company rules, working conditions or overnment/State Legislation.
Use of gloves may help prevent injury by keeping **hands warm** and dry.
2. For maximum safety wear ear protection within a 16 metre (17¹/₂ yards) distance of Wrench.
FILL the fuel tank carefully **BEFORE** starting the Wrench in a well **ventilated** area and avoid spillage. Use the Fuel Funnel provided and Safety Fuel Cans and **DO NOT** fill or add oil while the Motor is running or if the tank is hot. Keep well **away from** naked flames or equipment which generates **sparks** e.g. Rail Saw or Grinder. Mix the quantity needed. Do not leave the mixture in the fuel tank or container for a prolonged period of time.
3. Use only **IMPACT QUALITY** Sockets and Accessories.
Using worn Sockets on a good Square Drive or good Sockets on a worn Square Drive will **increase vibration** levels with resultant damage to both operator and Wrench. **HAND** Sockets must **NEVER** be used.
4. Use Rubber Rings and Steel Pins or other suitable retaining devices to retain the Socket or Accessory onto the Square Drive.
DO NOT use twigs, wire, nails or plastic straps.
5. Check the Wrench for damage regularly. Ensure fasteners are tight at all times. A poorly maintained Wrench will be inefficient and produce extra noise and vibration.
6. Check pull cord is not frayed nor worn.
7. Know where the controls are and how to use them and be able to **STOP** the Wrench quickly in an emergency.
8. Do not wear hanging jewellery, a tie or **LOOSE** or torn clothing when using equipment.
9. **DO NOT** operate the Wrench in a **CONFINED** area, where exhaust fumes (**CARBON MONOXIDE**) may collect.
10. Set the **GEAR CONTROL** in **NEUTRAL** before starting.
11. Take up a **FIRM** footing and maintain a balanced body position.
12. Switch **OFF ENGINE** **BEFORE** transporting the Wrench to another location.
13. Take **CARE** when **LIFTING** or carrying the Wrench - weight with fuel and excluding accessory 18.2 Kgs (40 1/3 lbs).
14. Remove **FUEL FILLER CAP CAREFULLY** as pressure can build up in the tank. This is very important in warm weather, if the Wrench has been left in an exposed area or after prolonged periods of use.
15. Always auger or fit fasteners on one of the **LOW** torque settings and use a **HIGH** one for removing fasteners.

**SAFETY IS EVERYONE'S RESPONSIBILITY
THINK, ACT, BE SAFE**

4. TECHNICAL INFORMATION

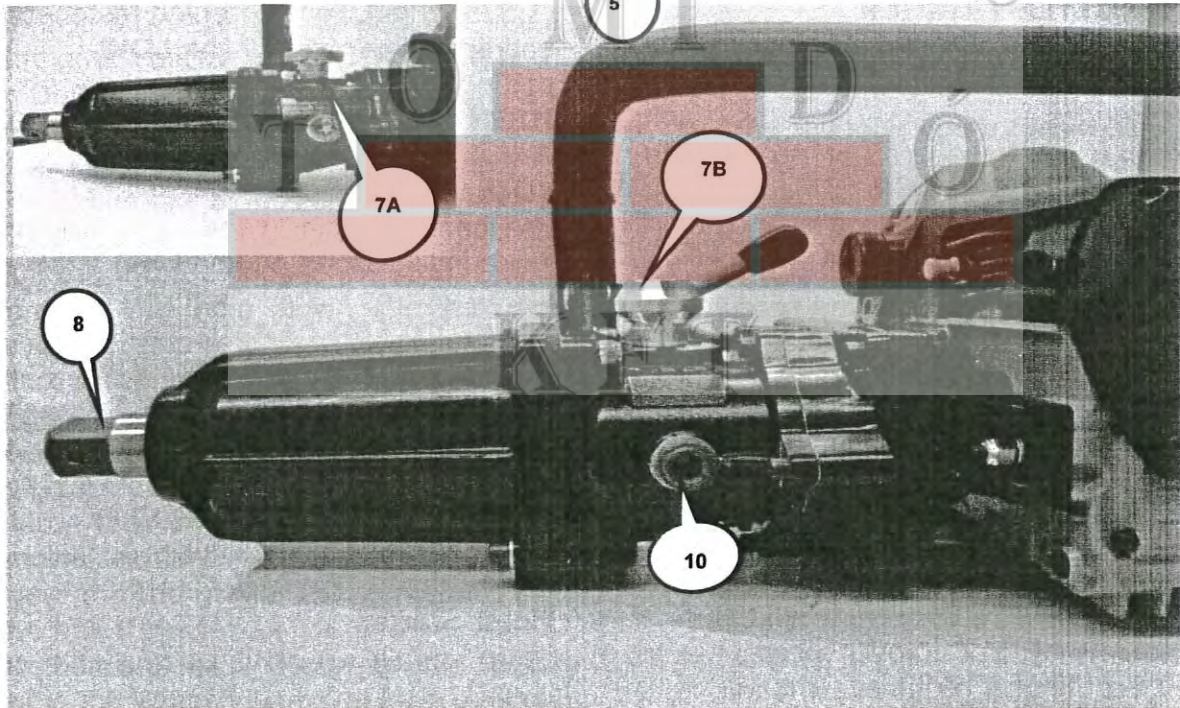
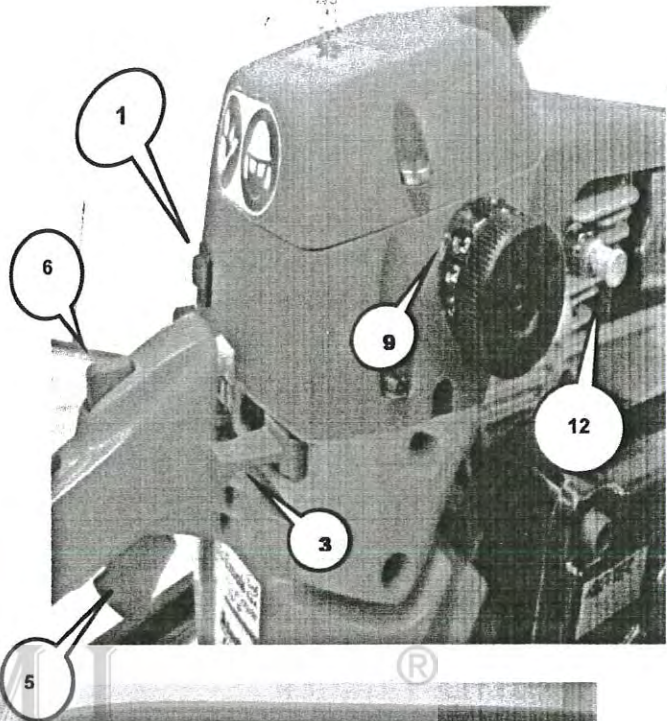
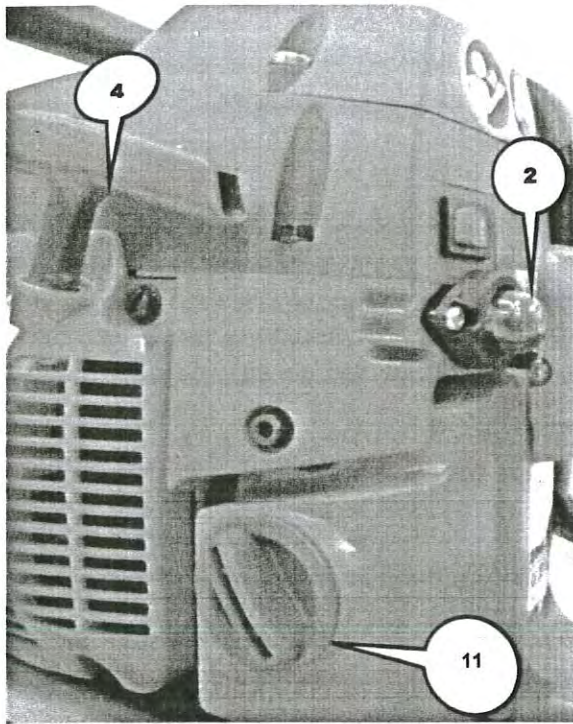

- (1) ON/OFF CONTROL SWITCH
- (2) FUEL PRIMER BULB
- (3) CHOKE LEVER
- (4) RECOIL STARTER

- (5) THROTTLE TRIGGER
- (6) HALF SPEED LEVER
- (7A) KNOB TYPE
- (7B) LEVER TYPE
- (8) SQUARE DRIVE

- (9) TORQUE SETTING LEVER
- (10) OIL FILLER PLUG
- (11) FUEL FILLER CAP
- (12) DE-COMPRESSION BUTTON

Note : The Serial Number can be found on Motor Flange (2600.1640)

5. OPERATING CONTROLS (See Page 3 for easy identification)

- 1. ON/OFF CONTROL WITCH**
To **START**, move the switch to **I**.
To **STOP** move to **STOP**.
- 2. FUEL PRIMER BULB**
Makes starting easy.
Press bulb three/four times before using recoil starter handle.
- 3. CHOKE LEVER**
Pull out to start and push in after Motor fires.

- 4. RECOIL STARTER**
Start Motor by pulling the recoil starter
Always allow the Starter Cord to return to its position under control and **DO NOT** allow it to fly back.
- 5. THROTTLE TRIGGER**
When the throttle trigger is squeezed the Motor speed increases.
- 6. HALF SPEED LEVER**
To operate hold down the lever, then release the trigger and it will hold in position.
- 7. FORWARD/REVERSE CONTROL KNOB** This has three positions: marked **N, F** and **R**
N - Neutral
F - Clockwise Rotation
R - Anti-clockwise Rotation
To engage turn **fully** 90 degrees from the Neutral position.
The gears are stationary when the Motor is idling at tickover speed.
Select the gear required. If it will not engage, gently squeeze the throttle trigger so the gear parts move slightly.
- 8. SOCKET SQUARE DRIVE**
Standard 1 inch Square Drive. The Accessory is secured to the Square Drive by a Rubber Ring and a 5mm dia Bright Steel Pin or other suitable retaining device. If the Pin breaks or bends examine both Accessory and Square Drive for possible wear.
Worn Accessories **damage the Square Drive**. A worn Square Drive **damages Accessories** and both create extra vibration.
Replace when worn.
- 9. TORQUE SETTING LEVER**
This has five positions allowing a range of torques to be selected.
LOW settings normally 500Nm (350 Ft/lbs) and **HIGH** setting 1800Nm (1,325 Ft/lbs). For tightening fasteners and drilling use one of the **LOW** settings and for removing fasteners a **HIGH** one.
- 10. OIL FILLER PLUG**
Use for filling, draining and indicating Gearbox oil level.
- 11. FUEL FILLER CAP**
Remove carefully when refilling the Fuel Tank.
- 12. DE-COMPRESSION BUTTON**
To assist in easy starting. Push in before starting. Comes out automatically when Motor Starts.

**OPEN TANK CAUTIOUSLY TO
RELEASE ANY PRESSURE SLOWLY
USE 2 STROKE/CYCLE OIL MIX ONLY
25:1 Mineral
50:1 Synthetic**

6. START/STOP OPERATION

1. FUEL MIXTURE

Mix = 1:25 Mineral or 1:50 Synthetic Oil to unleaded Petrol/Gasoline. Mix Oil and Petrol/Gasoline thoroughly in a **separate** Safety container before filling the tank. Only fill in a well ventilated area and away from equipment which generate sparks e.g. Rail Saws and Grinders.

REMEMBER: Using **too much** Oil will oil up the Spark Plug and **too little** causes extra wear.

2. PREPARATION FOR START-UP

Check oil level in the gear box is correct and that all nuts and screws are tight. Fill the fuel tank with the correct mixture

3. STARTING THE WRENCH

Place Wrench on a **SOLID** base and take a comfortable stance.

Slide Accessory onto Square Drive and secure with a Steel Pin and Rubber Ring or appropriate retaining device.

Set gear control in **NEUTRAL (N)**. Push in De-Compression Button (12). Pull choke lever (3) out.

Set ON/OFF Switch (1) to position I.

Fill Carburettor by pushing Fuel Primer Bulb (2) three/four times.

Pull the throttle trigger (5) stop it at half-throttle and hold down the half speed lever (6), and release trigger.

Place **heel** of boot on the **extended Handle base** or Roll Bar if fitted and pull the Recoil Starter slowly until resistance is felt, then pull hard several times. When the Motor fires return Choke lever (3) to its original position. Once the Motor starts, press throttle trigger (5) to release it from the half throttle

position and allow Motor to idle. Before using the Wrench warm up for a minimum period of thirty seconds.

NEVER accelerate to high speeds when in neutral.

4. OPERATING THE WRENCH

Always follow the "**SAFETY PRECAUTIONS**" shown on Page 2.

Position Wrench and Socket over fastener to be tightened/loosened and keep all three in a straight line.

Set Torque Lever and select the gear by moving gear control fully 90° to position F or R.

5. STOPPING THE WRENCH

Release throttle trigger and let Motor return to idle.

Turn off Motor by moving ON/OFF Switch to STOP position.

Set the Gear Control to **neutral (N)**

6. RE-FUELLING

ALWAYS open the Fuel Filler Cap **carefully** to release any pressure which may have built up. Cold fuel expands in a hot tank. Do not attempt to fill fuel tank if it is hot.

7. TUNING

The Carburettor is Factory set to meet E.P.A. regulations with Screws locked to permit only a half turn movement.

Do not force them further or the plastic cap locks will break.

Emission levels could then be in excess of the figures stated in our literature.

If the cap locks should be broken accidentally reset the Carb. screws :- Turn the high screw clockwise until it stops then anticlockwise 2¹/₈ turns.

Repeat this with the low screw setting at 2 turns.

These are basic settings and further slight adjustments may be necessary because of changes in climatic conditions and altitude. **Keep adjustments to a minimum.**

T idling speed
2,500 to 2,800 RPM
H maximum free
12,000 RPM speed

Once the Motor is warm DO NOT use the choke to start again.

Use the half throttle only when starting the engine.

DO NOT FILL OIL CHAMBER AT THE FRONT OF THE MOTOR

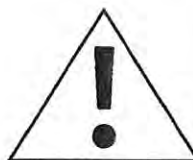

OPERATION & MAINTENANCE AIDS AVAILABLE
Operation Manual
Maintenance Manual
C.D. Rom - Safety Applications
Exploded Diagram Workshop Drawings
WEBSITE : www.airtecinternational.co.uk

7. BASIC WORKSHOP SAFETY RULES GUIDE

Only qualified trained Fitters should attempt to service or repair this equipment.

Your personal safety and those of your fellow workers is your responsibility.

Please observe all local and national regulations on safety. The undernoted list should be used as a guide.

1. Do not run or test any Two Stroke powered Engine in a Workshop or confined space. This can lead to a build up of poisonous gases and it generates unnecessary noise.
2. Empty fuel from the tank in a safe area before starting work on any Engine.
3. If the Wrench has not been used for some time empty and clean the fuel tank.
4. Under no circumstances smoke in a Workshop area. ®
5. Keep work areas clean and free from old oil, fuel and dirty rags which could ignite.
6. Do not leave petrol in open containers.
7. Use safety cans for the storage of fuel and do not keep more than the permitted legal quantity in any one place.
8. After repair, test the Wrench using clean properly mixed fuel and do so in a well ventilated area.

**SAFETY IS EVERYONE'S RESPONSIBILITY
THINK, ACT, BE SAFE**

8. ROUTINE SERVICE (See Exploded Diagram Drawings on Pages 9, 10 & 15)

1. REPLACING SPARK PLUG 4000.0809

Loosen two Filter Cover Screws 0180 and lift off Filter Cover 0990. Pull off Spark Plug Cover 0250. Unscrew Spark Plug and replace making sure the gap is set at between 0.5 and 0.6mm.

2. REPLACING AIR FILTER 4003.0451

Pull Air Filter 0451 from inside the Filter Cover 0990. Clean Filter and Filter Cover or if necessary, replace.

3. REPLACING FUEL FILTER 4001.1075

With the Machine in a vertical position open Fuel Cap 1090 cautiously to release any build up of pressure in the Fuel Tank. Pull out Fuel Filter and replace.

4. REPLACING STARTER CORD 4003.0340

Remove four Screws 0410 holding Starter Assembly 1171. Hold Pulley 1182 with thumb, cut old cord and allow Pulley to turn slowly back until no tension is left in Recoil Spring 04501. Remove Centre Screw 0690 and Washer 0700 and slowly lift off pulley. Fit new Cord through pulley and tie a knot. Feed other end of Cord through Starter Assembly 4003.1171 and into Starter Handle 0400 and again tie a knot. Locate Pulley in Recoil Spring and replace Centre Screw 0690 and Washer 0700. Locate Cord in the notch on outside of pulley, turn clockwise two complete turns then release. Repeat until the Starter Handle returns to the Housing locating hole when pulled out. Ensure correct length Screws 0410 are used when reassembling.

5. REPLACE GEAR BOX OIL

Remove three Screws 58 in Gear Selector 46 and remove from Gear Box. Empty out old oil. Fill gearbox with 0.25 litres (1/2 pint) of Esso Spartan EP68, Mobil Gerar 626, Carter EP68, Merpoa 68, Valvoline 80-90W or an equivalent non synthetic 68 viscosity Gear Oil. Replace Selector and fit screws using a suitable fastener locking fluid. **Change Oil every twelve months**

6. GREASING HAMMER AND ANVIL

Remove four Screws 90, 91, 95, Nuts 62 and Nose Casing. Clean out old grease and replace with 130 grammes (4¹/₂ ozs) of new **Molybdenum Disulphate Grease Grade 2**. Ensure this is pumped into holes on the side of Hammer Casing 83 and onto all eight striking faces.

Use of the correct quality grease will extend the life of both Anvil and Hammer.

7. ROUTINE MAINTENANCE INSTRUCTIONS

It is recommended a record of inspections and maintenance is kept and each Wrench is given a routine maintenance check after every 50 hours use.

This will reduce maintenance costs, improve efficiency and extend its useful life.

DAILY

Check all Bolts, Screws and Nuts for tightness and gearbox oil level.

WEEKLY

Clean Air Filter and Fuel Filter. If necessary use a suitable Solvent. Clean Spark Plug and check gap is 0.5 - 0.6mm

MONTHLY or every 25 hours use QUARTERLY or every 50 hours use

As above plus following:-
Clean internal Hammer and Anvil faces thoroughly and replace Grease.

Half yearly or every 100 hours use

Change Fuel Filter and check condition of Air Filter and Spark Plug

Use only GENUINE MASTER SPARE PARTS

This will cost less than using non original Spare Parts which generally don't last as long

Use of non-original parts reduces Wrench life, cancels Warranty and affects Product Liability cover.

8. RECORD KEEPING

It is recommended a record be kept of all servicing and repairs and Wrenches are labeled to show the next service date. This reduces maintenance cost and extends the Wrench's useful life.

9. DISMANTLING MOTOR (See Exploded Diagram Drawings on Pages 9, 10, 13 & 15)

1. REPLACE AIR FILTER 4003.0451

Unfasten two Screws 0180 on Filter Cover 0990 and lift off. Remove and replace Air Filter.

2. REMOVING TOP COVER 2870.1100

Loosen three Screws 0480. Push rubber air intake 1200 through Top Cover. Remove wires from On/Off Switch 0491 noting position for re-connecting. Refit using Air Intake Tool Part No. 4002 9005.

3. REPLACING FUEL PRIMER ASSEMBLY 4003.0810

Remove Screws 2303.0315 and take off Bulb Protector 4003.1046 and pull Primer from Motor.

Please note : for Primer re-connection connect Pipe 1190 from Fuel Tank to "out" port and Pipe 0910 from the Carburettor "in" port.

4. REPLACING STARTER RECOIL SPRING 4003.04501

Follow procedure for replacing Pull Cord - See 8.4 on Page 7.

With the pulley separated from Starter Housing, remove the two Screws.

Remove old Spring Cassette and replace with new one. Refit screws.

When refitting Starter Housing pull Starter Cord to ensure it operates before tightening Screws.

Please Note :
The Spring in the Cassette Case is re-tensioned. Always handle with care



5. REMOVING FLYWHEEL 4003.1077

Fit Piston Stop Tool 4000.0020 into Cylinder and remove Flywheel Nut 0040. Remove Flywheel Ratchet Assembly 1187. Using Puller 4000.0308 remove Flywheel. Take care not to lose Key 0220.

6. REMOVING EXHAUST GUARD 8 AND MUFFLER ASSEMBLY 4003.0850

Remove five Screws 7 holding Exhaust Guard and lift off. Unfasten two Screws 0640 on inside of Exhaust Box and remove it and Gasket 0860 from Motor. When re-assembling tighten screws to 16Nm (11 ft/lbs), warm Muffler by running Engine and tighten screws again. This ensures the Muffler is held on securely.

7. REMOVING THE CARBURETTOR 4003.0510

Remove two Screws 1188, Screw 0720 and Fuel Pipes 0190 & 0920 from Carburettor making sure to note re-connecting positions. Disconnect Choke Linkage 0880 and Throttle Linkage 1189 and remove Carburettor.

8. DISMANTLING MOTOR FROM IMPACT UNIT

Remove Carrying Handle 97 and four Screws 24 holding Clutch Support Flange 18 to Engine Flange 9. Pull apart.

9. REMOVING CYLINDER AND PISTON 4003.1165

Remove three Screws 0410 holding Carburettor Flange 0740 to Casing. Depress Spring Clip 0390 behind Carburettor Flange and pull from Cylinder. Loosen four Screws 0631 holding down Cylinder and lift off. Remove Spring Clip 4001 4200 from inside Piston and Gudgeon Pin 0800. Lift off Piston 1120. Check Piston Rings 0820 for wear and replace if necessary. Rebuild in reverse order.

Please Note: If Clutch is to be removed leave Cylinder and Piston in position until after this is done.

10. REMOVING CRANKCASE 4003.1173 & 4003.1079 FROM FUEL TANK 4003.1045

Remove seven Screws 4001.1100 (2), 4003.0090 (1) and 4003.0620 (4) to allow Crankcase to be disconnected from Fuel Tank.

11. REMOVING CRANKSHAFT 4003.0985

Remove seven Screws 4001.1100 (2), 4003.0090 (1) and 4003.0620 (4) from Clutch side of Crankcase. Run Flywheel Nut 0040 onto Crankshaft 0985 until flush with the end. Hold Crankcase tightly and using a soft faced mallet tap against the Flywheel Nut until the Casing splits.

Please Note:

- It is advisable to replace all Gaskets and Seals when rebuilding Motor.
- If Primer Bulb 0810 is burst disconnect two Fuel Pipes 0910 and 1190 and plug the holes.

DO NOT CONNECT THE PIPES TOGETHER Replace Primer Bulb Assembly as soon as possible. (see section 8.3)

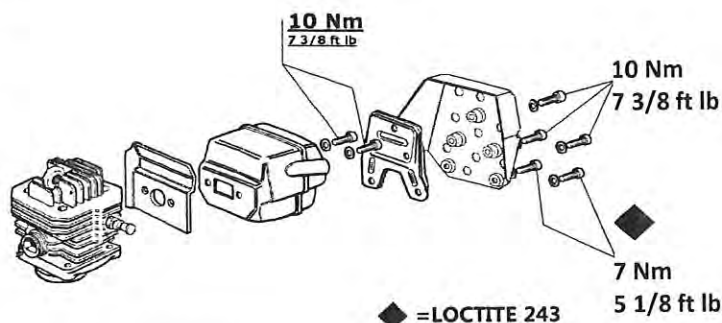

IMPORTANT!
Repeat when hot

10. MASTER MOTOR PARTS LIST

TOP COVER, AIR FILTER & CARBURETTOR

STARTER ASSEMBLY

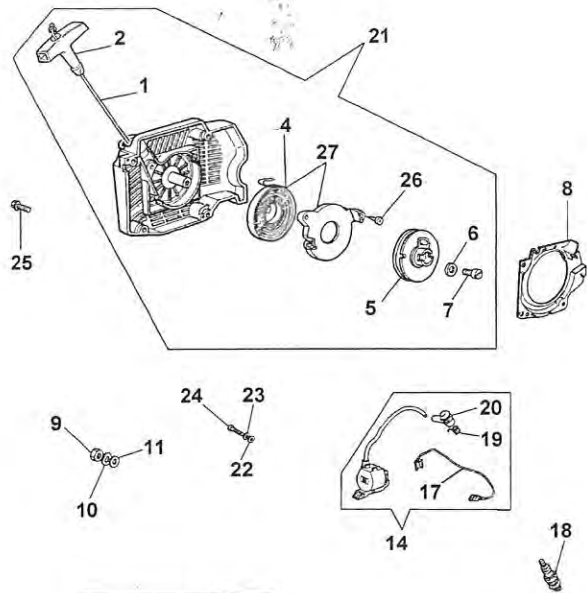
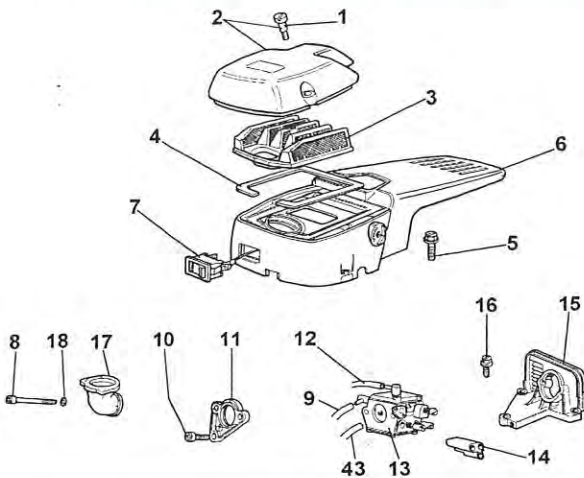

Page 9

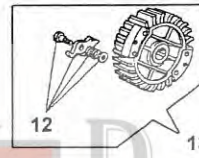
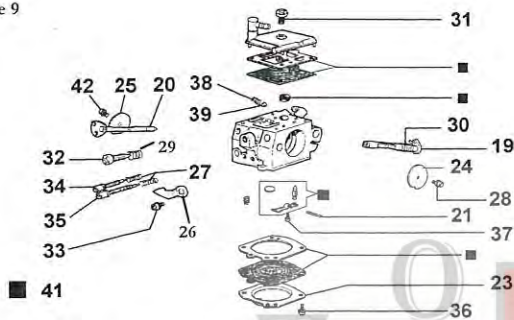

| Pos. | Pt No. | Description | Qty | Pos. | Pt No. | Description | Qty |
|------|-----------|--|-----|------|------------|---|-----|
| 1 | 4003.0180 | Screw | 2 | 1 | 4003.0340 | Recoil Starter Cord (4003.0405) | 1 |
| 2 | 4003.0990 | Air Filter Cover | 1 | 2 | 4003.0400 | Handle | 1 |
| 3 | 4003.0451 | Air Filter | 1 | 4 | 4003.0030 | Recoil Spring | 1 |
| 4 | 4003.0370 | Gasket | 1 | 5 | 4003.1182 | Pulley (4003.0360) | 1 |
| 5 | 4003.0480 | Screw | 3 | 6 | 4003.0700 | Washer | 1 |
| 6 | 4003.1170 | Top Cover Complete (2870.1100) (consists Gasket Pos. 4 & On/Off Switch Pos. 7) | 1 | 7 | 4003.0690 | Screw | 1 |
| 7 | 4003.0491 | On/Off Switch | 1 | 8 | 4003.0750 | Flange Cover | 1 |
| 8 | 4003.1188 | Screw (4003.0080) | 2 | 9 | 4003.0040 | Nut | 1 |
| 9 | 4003.0920 | Pipe | 1 | 10 | 4003.0670 | Washer | 1 |
| 10 | 4003.0720 | Screw | 1 | 11 | 4003.0070 | Washer (50.300361) | 1 |
| 11 | 4003.1070 | Spacer | 1 | 12 | 4003.1187 | Flywheel Ratchet Assembly | 1 |
| 12 | 4003.0190 | Pipe | 1 | 13 | 4003.1186 | Flywheel Assembly | 1 |
| 13 | 4003.0510 | Carburettor | 1 | 13 | 4003.1077 | Up to ATE08A999 Flywheel Assembly | 1 |
| 14 | 4003.1010 | Screen Guide | 1 | 14 | 4003.1180 | Coil Assembly BLUE | 1 |
| 15 | 4003.0740 | Carburettor Flange | 1 | 14 | 4003.1176 | Coil Assembly (No longer available) | 1 |
| 16 | 4003.0410 | Screw | 3 | 14 | 4003.1178 | Coil Assembly (replaces 4003.1176 21/04/09) | 1 |
| 17 | 4003.1200 | Rubber Air Intake (4003.0770) | 1 | 15 | 4003.0491 | Switch (on/Off) | 1 |
| 18 | 4000.0880 | Washer | 2 | 16 | 4003.0420 | Lead | 1 |
| 19 | 4003.0930 | Shaft Assembly Throttle | 1 | 17 | 4003.0430 | Lead up to ATE08A999 | 1 |
| 20 | 4003.0940 | Shaft Assembly Choke | 1 | 17 | 4003.1078 | Lead From ATE08B001 | 1 |
| 21 | 4003.0000 | Pin | 1 | 18 | 4000.1620 | Spark Plug | 1 |
| 22 | 4003.0950 | Cover | 1 | 19 | 4003.0290 | Spring | 1 |
| 23 | 4003.0497 | Throttle (4003.0260) | 1 | 20 | 4003.0250 | Plug Cap | 1 |
| 24 | 4003.0497 | Throttle (4003.0260) | 1 | 21 | 4003.1171 | Starter Assy (4003.1162) | 1 |
| 25 | 4003.0500 | Shuttle Disc | 1 | 22 | 4003.0696 | Washer (4002.0100) | 2 |
| 26 | 2650.0080 | Throttle Stop (2650.0050) | 1 | 23 | 4003.0120 | Washer (60.00315) | 2 |
| 27 | 4003.0310 | Spring | 2 | 24 | 4003.0200 | Screw | 2 |
| 28 | 4003.0610 | Screw | 1 | 25 | 4003.0410 | Screw | 4 |
| 29 | 4003.0280 | Spring | 1 | 26 | 4003.0096 | Screw (4003.0095) | 2 |
| 30 | 4003.0970 | Spring | 1 | 27 | 4003.04501 | Recoil Spring Assembly | 1 |
| 31 | 4003.0980 | Screw | 1 | | | | |
| 32 | 4003.0170 | Screw | 1 | | | | |
| 33 | 4003.0020 | Screw | 1 | | | | |
| 34 | 4003.0540 | Screw | 1 | | | | |
| 35 | 4003.0530 | Screw | 1 | | | | |
| 36 | 4003.0160 | Screw | 4 | | | | |
| 37 | 4003.0010 | Screw | 1 | | | | |
| 38 | 4003.0300 | Spring | 1 | | | | |
| 39 | 4003.0270 | Ball | 1 | | | | |
| 41 | 4003.0493 | Carb. Kit | 1 | | | | |
| 42 | 4003.0610 | Screw | 1 | | | | |
| 43 | 4003.1190 | Pipe | 1 | | | | |

Please Note :
New ignition system fitted from Serial No. ATE08B001 February 2008

10. MASTER MOTOR PARTS LIST

CYLINDER & PISTON

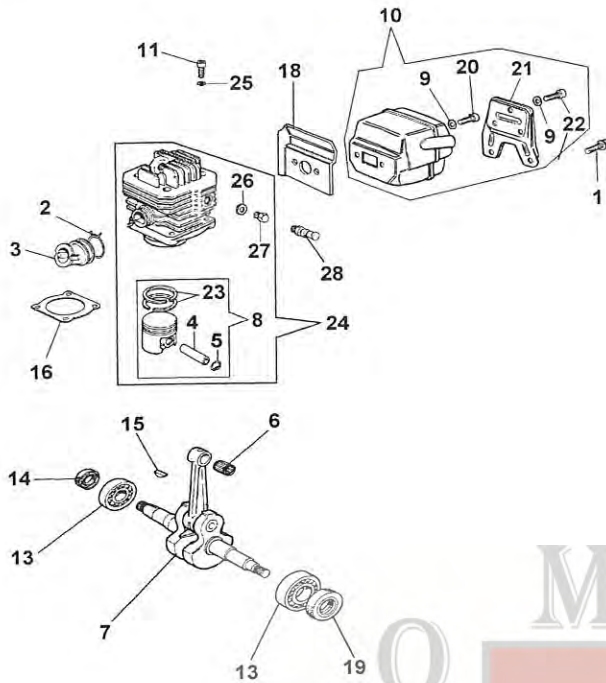

CRANKCASE & FUEL TANK

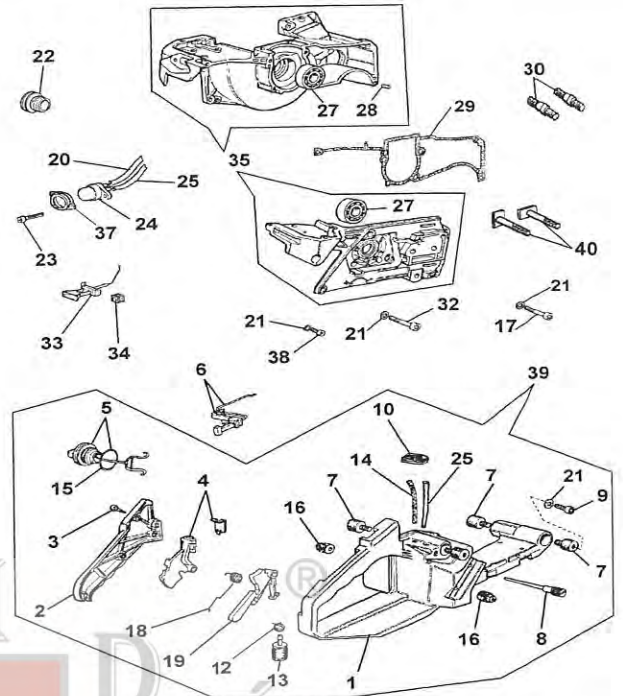

| Pos. | Pt No. | Description | Qty | Pos. | Pt No. | Description | Qty |
|------|-----------|---------------------------|-----|------|-----------|--------------------------------|-----|
| 1 | 2300.0520 | Screw 7Nm | 2 | 1 | 4003.1045 | Fue lTank Only | 1 |
| 2 | 4003.1181 | Hose Clamp (4003.0390) | 1 | 2 | 4003.1060 | Handle Cover | 1 |
| 3 | 4003.0760 | Manifold | 1 | 3 | 4003.0710 | Screw | 3 |
| 4 | 4003.0800 | Gudgeon Pin | 1 | 4 | 4003.1040 | Lever | 1 |
| 5 | 4001.4200 | Spring Clip | 2 | 5 | 4003.1090 | Fuel Cap | 1 |
| 6 | 4003.0580 | Bearing | 1 | 6 | 4003.1189 | Throttle Linkage (4003.1020) | 1 |
| 7 | 4003.0985 | Crankshaft | 1 | 7 | 4003.0350 | Rubber Mount | 4 |
| 8 | 4003.1120 | Piston Assy 46mm dia | 1 | 8 | 4003.0460 | Breather | 1 |
| 9 | 2400.1050 | Washer (AT version) (7) | 5 | 9 | 4000.8770 | Screw | 4 |
| 10 | 4003.0850 | Muffler Assy (AT version) | 1 | 10 | 4003.0780 | Grommet | 1 |
| 11 | 4003.0631 | Screw (4003.0630) | 4 | 12 | 1708.0070 | Fastener Clip | 1 |
| 13 | 4000.0378 | Bearing | 2 | 13 | 4003.1075 | Fuel Filter (4001.9100) | 1 |
| 14 | 4003.0210 | Seal | 1 | 14 | 4003.0920 | Pipe | 1 |
| 15 | 4003.0220 | Key | 1 | 15 | 4003.0470 | 'O' Ring | 1 |
| 16 | 4003.0830 | Gasket | 1 | 16 | 4003.0870 | Rubber Mount | 2 |
| 18 | 4003.0860 | Gasket Insulator | 1 | 17 | 4001.1100 | Screw | 2 |
| 19 | 4001.4320 | Seal | 1 | 18 | 4003.0330 | Spring | 1 |
| 20 | 4003.0640 | Screw 10Nm | 2 | 19 | 4003.0320 | Throttle Lock | 1 |
| 21 | 4003.1030 | Muffler Cover | 1 | 20 | 4003.1190 | Pipe Tubing | 1 |
| 22 | 2300.0520 | Screw 9Nm | 3 | 21 | 4000.0880 | Washer | 11 |
| 23 | 4003.0820 | Piston Ring 46mm dia | 2 | 22 | 4003.1184 | Cap (4001.5462) | 1 |
| 24 | 4003.1165 | Cylinder Assy. 46mm dia | 1 | 23 | 2303.0315 | Screw | 2 |
| 25 | 4000.0885 | Washer | 4 | 24 | 4003.0810 | Primer Assembly | 1 |
| 26 | 4003.0595 | Washer | 1 | 25 | 4003.0592 | Pipe Tubing (4003.0910) | 1 |
| 27 | 4003.1185 | Plug | 1 | 27 | 4000.0378 | Bearing | 2 |
| 28 | 4003.1073 | De-Compression Button | 1 | 28 | 4003.0550 | Pin | 2 |
| | | | | 29 | 4003.0840 | Gasket | 1 |
| | | | | 30 | 4003.0230 | Stud Bolt | 2 |
| | | | | 32 | 4003.0620 | Screw | 4 |
| | | | | 33 | 4003.0880 | Choke Linkage | 1 |
| | | | | 34 | 4003.0380 | Grommet | 1 |
| | | | | 35 | 4003.1081 | Crankcase Assembly with Coil | 1 |
| | | | | 37 | 4003.1046 | Bulb Protector (2650.1010) | 1 |
| | | | | 38 | 4003.0090 | Screw (4003.0675) | 1 |
| | | | | 39 | 2800.0001 | Fuel Tank Complete Assy | 1 |
| | | | | 40 | 4003.1175 | Stud Bolt | 2 |
| | | | | | 4003.1140 | Gasket Set consisting of :- | |
| | | | | | | 4003.0370,4003.0830, 4003.0840 | |

11. MASTER MOTOR PARTS LIST NOTES

1. STANDARD MASTER 35 Impact Wrench pre 2000 can be converted into new style using Motor Conversion Kit Part No. 2810.1004
 Last Serial No. for STANDARD Master 35 ATD 00A44 approximately December 1999
 First Serial No. for NEW Master 35 ATE 99A01 approximately January 2000
2. New Digital Ignition System fitted from February 2008
 Serial No. ATE08B001
 Crankcase Assembly with Coil 4003.1081 is a suitable replacement for all machines.
3. Cylinder 4003.1130 replaced by De-Compression version 4003.1165 and Button 4003.0885
 From Serial No. ATE00 M01
4. Part Number Changes

| Old | Description | New |
|-----------|-----------------|--------------|
| 2650.0050 | Throttle Stop | 2650.0060 |
| 4000.1620 | Spark Plug | 4000.0809 |
| 4001.5461 | Cap | 4001.5462 |
| 4003.0440 | Ratchet Assy | 4003.1187 |
| 4003.0450 | Air Filter | 4003.0451 |
| 4003.0490 | On/Off Switch | 4003.0491 |
| 4003.0730 | Crankshaft | 4003.0985 |
| 4003.1186 | Flywheel Assy. | 4003.1077 |
| 4003.0890 | Starter Housing | 4003.1043 ** |
| 4003.1025 | Screw | 4003.0610 |
| 4003.1080 | Starter Assy. | 4003.1162 |
| 4003.1160 | Half Crankcase | 4003.1079 |
5. Top Cover complete 2870.1100 comprises the following parts :-

| | |
|----------------------|-----------|
| Top Cover | 4003.1170 |
| On/Off Switch | 4003.0491 |
| Gasket | 4003.0370 |
| Cam with Shaft | 2570.0050 |
| Regulator Spring | 2170.0030 |
| Torque Control Lever | 035588 |
| Screw | 135593 |
6. Fuel Tank only 4003.0900 replaced by 4003.1045
7. Recoil Spring 4003.0030 now supplied as an Assembly 4003.04501
8. Stud Bolt 4003.1175
 Replaces Stud Bolt 4003.0230 from Machine No. 02L044
9. **Starter Housing 4003.1043 no longer available 01/02/06. Order Starter Assembly 4003.1162
10. Coil Assembly (Black) 4003.1176 no longer available 21/04/09. Order Coil Assembly 4003.1178
11. Carb. Gasket Set 4003.1000 and Carb. Repair Kit 4003.1050 no longer available individually.
 Order Carb. Kit 4003.0493
12. Special Motor Parts (AT Version)
 - a) Carburettor 4003.0510 – A standard Carb runs at a higher speed.
 - b) Muffler Assembly 4003.0850 – A standard one has shorter screws.
 - c) Crankcase Assembly 4001.4300 – Is made of stronger Aluminium Alloy to support the weight of the impact unit.

Fit only genuine AT parts to ensure best performance and a long reliable life.

12. DISMANTLING IMPACT UNIT (See Exploded Diagram Drawings on Page 13&15)

1. REMOVING CLUTCH SUPPORT FLANGE 18

Remove Gear Selector 46 and empty oil from Gearbox 30. Remove six Screws holding Clutch Support Flange to Gearbox and pull apart.

2. REMOVING CLUTCH 16 AND MOTOR FLANGE 9

Remove Spark Plug 0060 and fit Piston Stop Tool 4000.0020. Turn Clutch Nut 16 in clockwise direction. Loosen two Lock Nuts 12 holding Motor Flange to Motor and pull off Flange.

To replace Motor Flange Bearing 13 press out and replace. Assemble in reverse order.

3. REPLACING SEAL 19 & BEARINGS 20 IN CLUTCH SUPPORT FLANGE 18 Remove Circlip 21 and using a soft face mallet tap out Clutch Ring 17. Remove Circlip 22 and from the opposite side push out Bearings 20. Remove Oil Seal 19 and replace if necessary. Assemble in reverse order.

4. DISMANTLING GEARBOX 29

Remove Circlip 27 and lift off Gear 28. Remove Ring Flange 67 and check Bearings 66 & 69 and Oil Seal 68 for wear or damage. Remove Bearing Shaft 42 and check. Remove Circlip 31 and from the opposite side tap out Selector Shaft 33. Using a 5mm Screw extract Planet Pivot 39 by holding the Screw Head in a vice and tap Gearbox with a soft face mallet. Remove Planet Gear 38 and Spacer 36.

Please Note: The Planet Gear has a chamfered edge which MUST be re-fitted in the same way as before.

Take out Gear Cluster 41 and note directions for re-building. Assemble in reverse order.

5. DISMANTLING HAMMER COMPLETE

78 Place complete Hammer length ways in a vice with one hole uppermost. Carefully tighten vice until Steel Ball 76 drops out of lower hole (a short blast of air will assist this operation). Loosen vice and turn Hammer 83 through 180° degrees and repeat previous instruction to allow second ball to be removed. Slowly loosen vice again. Hammer Casing 83 and Catch 71 can now be separated. Remove Shaft 75, Spring 77 and Bearing 74 and inspect for wear. Using Circlip Pliers remove Seeger Rings 79 from Hammer Casing. Tap off Steel Ring 80 with a punch, Knock out four Steel Plugs 82 from inside to allow Cam 81 to be removed from Hammer Casing.

Please Note:

Always renew the Steel Plugs before rebuilding.

Inspect Anvil 84 and Hammer 83 striking faces for wear or damage. These are critical areas which will affect the Wrench's performance.

Inspect all parts for wear or damage and replace, grease up and re-build in reverse order.

Fit new Gasket 85 and refit Nose Casing 86.

Please Note: It is advisable to replace Seals, 'O' Rings and Gaskets when rebuilding the Impact Unit.

6. ANVIL 84

The Square Drive is 25.4mm. If this wears by 1mm or more replace it immediately.

Failure to do so will increase vibration and damage Sockets

13. MASTER MOTOR & CARRYING HANDLE

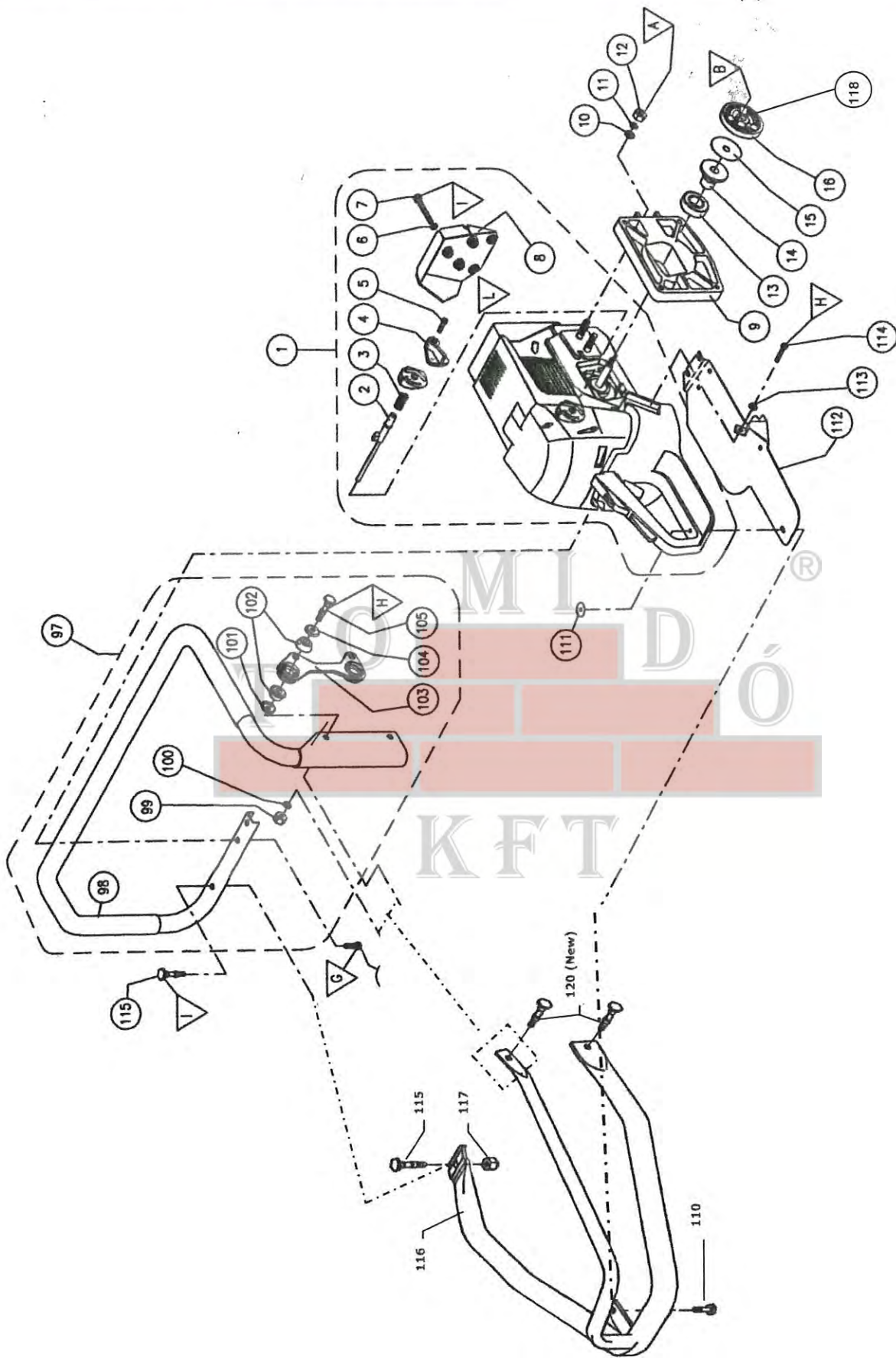

14. MASTER MOTOR & CARRYING HANDLE PARTS LIST

| Pos. | Pt No. | Description |
|------|-----------|---------------------------------|
| 1 | 2810.1030 | Motor Complete |
| 2 | 2570.0050 | Cam with Shaft |
| 3 | 2510.0030 | Regulator Spring |
| 4 | 2670.3000 | Torque Control Lever 035588 |
| 4 * | 2670.3020 | Torque Control Lever |
| 5 | 2304.0516 | Screw 135593 |
| 5 * | 2300.0510 | Screw |
| 6 | 2400.1050 | Washer (5) 135597 |
| 7 | 2300.0520 | Screw (5) |
| 8 | 2650.1400 | Exhaust Guard |
| 9 | 2600.1640 | Motor Flange |
| 10 | 2400.2080 | Washer (7) 135571 |
| 11 | 2400.1080 | Washer (7) 135570 |
| 12 | 2310.2061 | Lock Nut (3) 135569 |
| 13 | 2332.0201 | Bearing |
| 14 | 2540.0140 | Bearing Flange 2540.0130 |
| 15 | 4003.0600 | Clutch Disc |
| 16 | 4003.1110 | Clutch Complete |
| 97 | 2800.4030 | Handle Complete |
| 98 | 2620.5100 | Handle |
| 99 | 2310.2061 | Lock Nut (2) |
| 100 | 2400.2060 | Washer (2) |
| 101 | 4000.3290 | Rubber Mount Washer (2) |
| 102 | 4000.3180 | Rubber Mount (4) 54.00227 |
| 103 | 2650.2000 | Bracket 035129 |
| 104 | 4000.3300 | Rubber Mount Washer (2) 5400563 |
| 105 | 2580.0080 | Screw (2) |
| 106 | 2305.0620 | Screw (2) |
| 110 | 2580.0050 | Screw |
| 111 | 2700.0200 | Threaded Plate |
| 112 | 2650.1050 | Fuel Tank Wear Plate |
| 113 | 2400.2060 | Washer |
| 114 | 2305.0620 | Screw |
| 115 | 2580.0814 | Screw |
| 116 | 2800.4045 | Rollbar Only |
| 117 | 2310.2061 | Nut |
| 118 | 4003.0050 | Clutch Spring |
| 120 | 2580.0085 | Screws for Rollbar (2) |

* From Serial No. ATE 09L039 July 2009

14. MASTER IMPACT UNIT AND GEARBOX

KNOB 035107

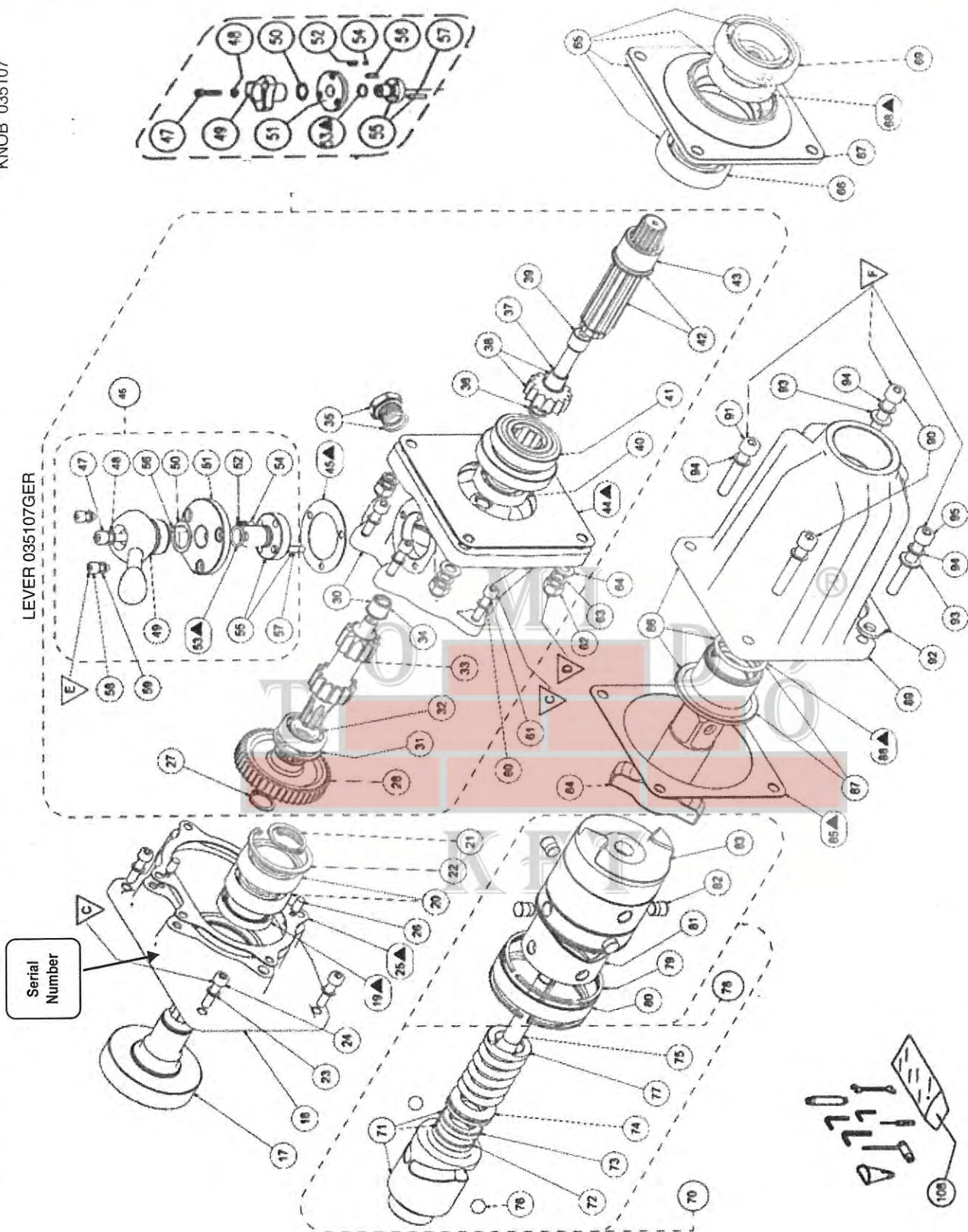























14. MASTER IMPACT UNIT AND GEARBOX PARTS LIST

| Pos. | Pt No. | Description | Pt No. | Description |
|------|-----------|--------------------------------------|------------|--------------------------------|
| 17 | 2690.7710 | Clutch Ring | 57 | 035113 Selector Pin |
| 18 | 2600.3130 | Clutch Support Flange | 58 | 135116 Screw (3) |
| 19 | 2343.0420 | Oil Seal | 59 | 135597 Washer (7) |
| 20 | 2332.0250 | Bearing (2) | 60 | 135513 Washer (19) |
| 21 | 135553 | Circlip | 61 | 135515 Screw (9) |
| 22 | 135552 | Circlip | 62 | 135569 Lock Nut |
| 23 | 135513 | Washer(10) | 63 | 135570 Spring Washer (3) |
| 24 | 135515 | Screw | 64 | 135571 Washer |
| 25 | 035514 | Gasket | 65 | 035303 Ring Flange complete |
| 26 | 035554 | Pin (2) | 66 | 135558 Bearing |
| 27 | 135508 | Circlip | 67 | 035561 Ring Flange |
| 28 | 2640.7000 | Gear | 68 | 135559 Oil Seal |
| 29 | 035305 | Gearbox complete | 69 | 135531 Bearing |
| 30 | 035105 | Gearbox Casing c/w Bronze Bush 34 | 70 | 035309 Impact Complete |
| 31 | 135516 | Circlip | 71 | 035565 Catch |
| 32 | 102020 | Bearing | 72 | 035586 Stop Bush |
| 33 | 035119 | Selector Shaft | 73 | 035585 Guide Bush |
| 34 | 035548 | Bronze Bush | 74 | 135532 Bearing |
| 35 | 135520 | Oil Plug & Felt Washer | 75 | 035567 Central Shaft |
| 36 | 035550 | Spacer | 76 | 135539 Steel Ball (2) |
| 37 | 035548 | Bronze Bush | 77 | 035566 Spring |
| 38 | 035551 | Planet Gear c/w Bronze Bush | 78 | 035302 Hammer Assembly |
| 39 | 035549 | Planet Pivot | 79 | 135533 Seeger Ring (2) |
| 40 | 103020 | Bearing | 80 | 035536 Steel Ring |
| 41 | 035104 | Gear Cluster | 81 | 035538 Cam |
| 42 | 035102 | Bearing Shaft c/w Bush 43 | 82 | 035537 Steel Plug (4) |
| 43 | 035103 | Bush | 83 | 035568 Hammer |
| 44 | 035560 | Gasket | 84 | 035572 Anvil |
| 45 | 035115 | Gasket | 85 | 035562 Gasket |
| 46 | 035304 | Gear Selector Complete | 86 | 035301 Nose Casing Complete |
| 47 | 135506 | Screw | 87 | 033005 Nose Bush with 'O' Ring |
| 48 | 135513 | Washer | 88 | 135542 'O' Ring |
| 49A | 035107 | Gear Change Knob | 90 | 135575 Screw (2) |
| 49B | 035107GER | Gear Change Lever | 91 | 135564 Screw |
| 50 | 135110 | Bevel Washer | 92 | 135153 Footrest |
| 51 | 035111 | Gear Flange | 93 | 135571 Washer (7) |
| 52 | 035523 | Spring | 94 | 135570 Washer (7) |
| 53 | 135114 | 'O' Ring | 95 | 135563 Screw |
| 54 | 104051 | Ball | 108 | 1140.1010 Maintenance Toolkit |
| 55 | 035112 | Gear Selector | | |
| 56 | 035554 | Pin | 2890.1050 | Gasket Set |
| | | | Consisting | |
| | | | 2343.0420 | Oil Seal |
| | | | 135559 | Oil Seal |
| | | | 135114 | 'O' Ring |
| | | | 135542 | 'O' Ring |
| | | | 035560 | Gasket |
| | | | 035514 | Gasket |
| | | | 035115 | Gasket |
| | | | 035562 | Gasket |

15. MASTER IMPACT & GEARBOX UNIT NOTES

1. FASTENER INFORMATION & TORQUES

See drawings on Pages 13 and 15.

| Pos | Screw Head Sizes | Removal Direction | Torque Settings Nm Ftilbs. | | Notes |
|-----|--|--|-------------------------------|-------------|-----------------|
| A |  13m |  OFF | 23 | 17.0 | |
| B |  19m |  OFF | 33 | 24.3 | |
| C |  5mm |  OFF | 16 | 11.8 | |
| D |  13m |  OFF | 33 | 24.3 | |
| E |  4mm |  OFF | 6 | 4.4 | Loctite 243 |
| F |  6mm |  OFF | 33 | 24.3 | |
| G |  8m |  OFF | 6 | 4.4 | Loctite 243 |
| H |  4mm |  OFF | 9 | 6.6 | Repeat when hot |
| I |  13mm |  OFF | 9 | 6.6 | |
| L |  3mm |  OFF | 2 | 1.5 | |
| M |  13m |  OFF | 6 | 4.4 | |

2. Impact Unit Complete 2870.0650

3. Toolkit 1140.1010

The Toolkit contains the following.

Toolkit in Bag Complete TK1

Allen Key 4mm TK2 for 5mm Cap Screws

Allen Key 5mm TK3 for 6mm Cap Screws

Allen Key 6mm TK4 for 8mm Cap Screws

Double Open Ended

Spanner 13mm x 10mm TK5 for Clutch Nut and M10 Hex Screw respectively TK7

Spark Plug

Spanner TK8 Minor Carburettor adjustments

Screwdriver TK9

Fuel Funnel

4. PART NUMBER CHANGES

| Old | Description | New |
|----------|----------------|-----------|
| 28101031 | Motor Complete | 2810.1030 |
| 23430520 | Oil Seal | 2343.0420 |

5. PARTS ORDERING PROCEDURE

When ordering parts please show Quantity, Description and Part Number e.g.

| QTY | DESCRIPTION | PART NO. |
|-----|--------------|-----------|
| 4 | Fuel Filters | 4001.9100 |

16. WORKSHOP EQUIPMENT

To carry out repairs and maintenance work effectively

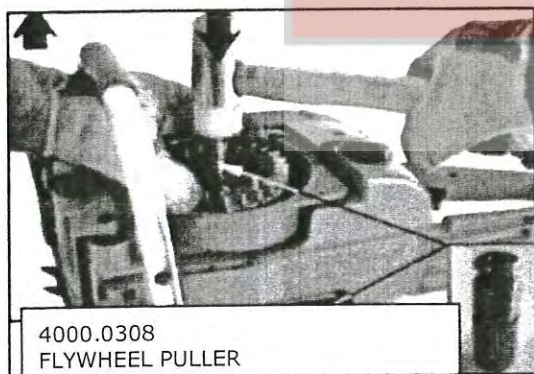
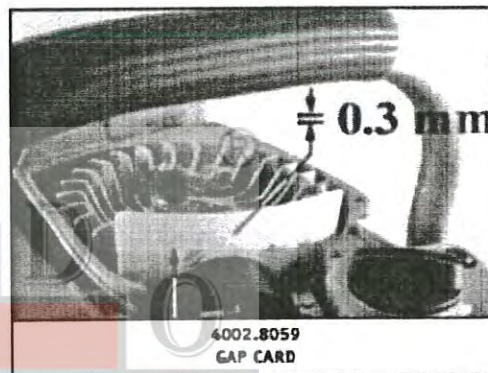
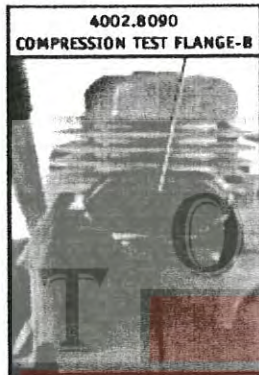
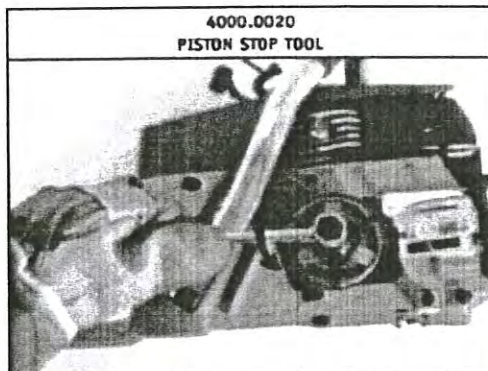

KFT

Buy your GENUINE SPARE PARTS & ACCESSORIES FROM

17. ACCESSORIES

1. METAL CARRYING BOX

Strong Metal Carrying Box with full length hinged lid, lockfast fitting, twin carrying handles and anti-slip rubber base. Holds an Impact Wrench, Sockets, Augering Attachment, Bits, Clips and Oil etc

Weight 11.7 Kgs (26lbs)
Dimensions 590 x 455 x 296mm
(23 1/2" x 18 1/8" x 11 1/2")

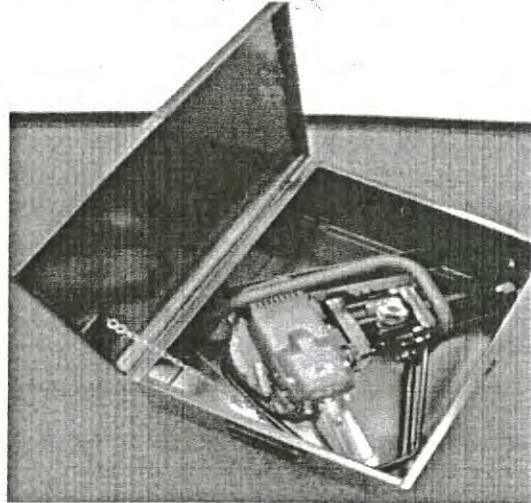

2. IMPACT ACCESSORIES

STANDARD AND DEEP RAILWAY QUALITY 1" IMPACT SOCKETS

Hexagon 21 to 46mm, Square 21 to 25mm
Rectangular 19 x 17, 25 x 18 and 28 x 21mm
Bi-Square 7/8" to 2 1/4"

For use on Impact Wrenches and Track
Screwing Machines

EXTENSIONS 125 to 450mm (6" to 18"
long), **UNIVERSAL JOINTS, MAXI CLIPS,**
RUBBER RINGS, STEEL PINS.

All other Square Drives and sizes available
on request

*Ensure Rubber Rings are a tight fit to retain the
Steel Pin. Natural Rubber stretches better than
Synthetic Rubber and lasts longer.*

*Steel Pins should be approximately 2mm (1/16")
shorter than the diameter of the Socket groove*

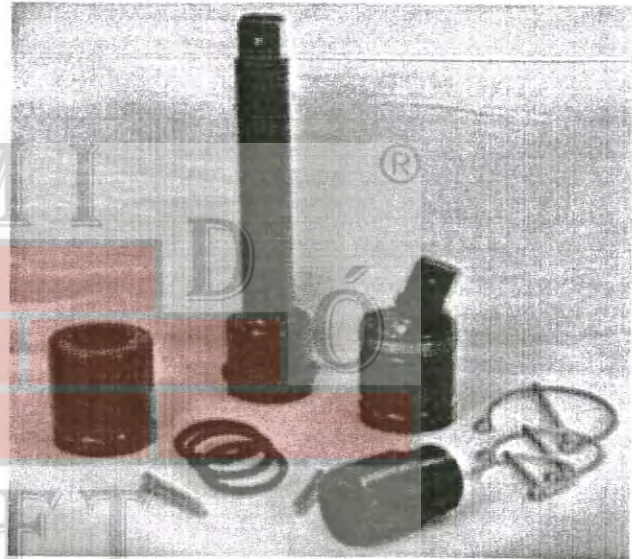

3. AUGER ACCESSORIES

SAFETY QUICK RELEASE AUGERING ATTACHMENT

For European and American Hexagon and
Railway Round Shank Bits

AUGER BITS

Standard and Premium Hardwood Quality
With 9mm Hex and all types of Railway
Round Shanks

10 to 22mm dia for drilling holes in all
types of timber Railway Sleepers.

Special shanks, lengths and other diameters
available on request

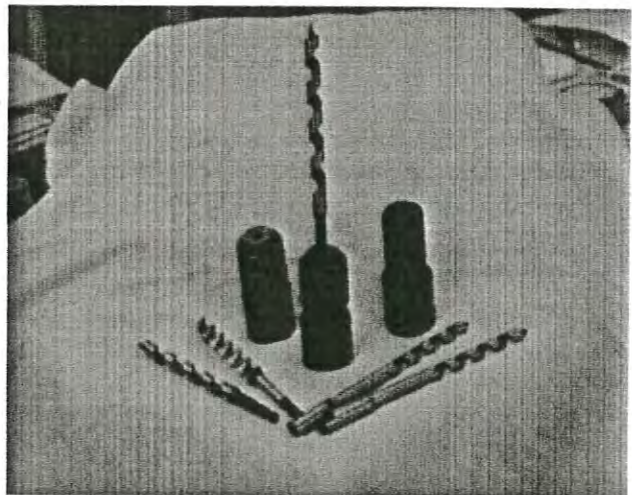

| | | |
|--|--|--------------|
| ACCESSORIES | | 17 |
| | Auger Bits | 17.3 |
| | Impact Sockets | 17.2 |
| | Metal Carrying Box | 17.1 |
| | Safety Quick Release Augering Attachment | 17.3 |
| | | |
| DISMANTLING IMPACT UNIT | | 12 |
| | Anvil | 12.6 |
| | Clutch & Motor Flange | 12.2 |
| | Clutch Support Flange | 12.1 |
| | Gearbox | 12.4 |
| | Hammer Complete | 12.5 |
| | Seal & Bearings | 12.3 |
| | | |
| DISMANTLING MOTOR | | 9 |
| | Air Filter | 9.1 |
| | Carburettor | 9.7 |
| | Crankcase from Fuel Tank | 9.10 |
| | Crankshaft | 9.11 |
| | Cylinder & Piston | 9.9 |
| | Exhaust Guard & Muffler Assy | 9.6 |
| | Flywheel | 9.5 |
| | Fuel Primer | 9.3 |
| | Motor from Impact Unit | 9.8 |
| | Starter Recoil Spring | 9.4 |
| | Top Cover | 9.2 |
| | | |
| EXPLODED DRAWINGS, PARTS LIST & NOTES | Impact & Gearbox | 13-15 |
| | Motor & Carrying Handle | 10-11 |
| | | |
| FASTENER | | 15 |
| | | |
| OPERATING CONTROLS | Illustrations | 4 |
| | Choke Lever | 5.3 |
| | De-Compression Button | 5.12 |
| | Forward/Reverse Control Knob | 5.7 |
| | Fuel Filler Cap | 5.11 |
| | Fuel Primer Bulb | 5.2 |
| | Half Speed Lever | 5.6 |
| | Oil Filler Plug | 5.10 |
| | On/Off Control Switch | 5.1 |
| | Recoil Starter | 5.4 |
| | Square Drive | 5.5 |
| | Throttle Trigger | 5.9 |

| | | |
|------------------------------------|----------------------------------|-----------|
| Routine Services | | 8 |
| | Air Filter | 8.2 |
| | Fuel Filter | 8.3 |
| | Gearbox Oil | 8.5 |
| | Grease Hammer & Anvil | 8.6 |
| | Record Keeping | 8.8 |
| | Starter Cord | 8.4 |
| | Routine Maintenance Instructions | 8.7 |
| | Spark Plug | 8.1 |
| Safety Precautions | | 3 |
| Start/Stop Operations | | 6 |
| | Fuel Mixture | 6.1 |
| | Operating the Wrench | 6.4 |
| | Preparation for Start-up | 6.2 |
| | Re-fuelling | 6.6 |
| | Starting Wrench | 6.3 |
| | Stopping Wrench | 6.5 |
| | Tuning | 6.7 |
| Technical Information | | 2 |
| | Torque Range | 2.1 |
| | Bolt Capacity | 2.2 |
| | Dimensions | 2.3 |
| | Exhaust Emission Levels | 2.5 |
| | Gearbox | 2.6 |
| | Ignition | 2.7 |
| | Impact Mechanism | 2.8 |
| | Motor | 2.4 |
| | Noise | 2.9 |
| | Square Drive | 2.10 |
| | Vibration | 2.11 |
| | Weight | 2.12 |
| Toolkit & Notes | | 15 |
| Uses | | 1 |
| Workshop Safety Rules Guide | | 7 |
| Workshop Equipment | | 16 |